

DIRECTIONAL DRILLING

V. S. ZAGORODNOV, J. J. KELLEY and B. R. KOCI

Polar Ice Coring Office, University of Alaska Fairbanks, Fairbanks, Alaska 99775-1710, U. S. A.

Abstract: Directional Drilling (DD) technology can be used in deep glacier boreholes to obtain additional ice cores from any depth and create supplemental boreholes for geophysical research on glacier ice properties under natural conditions. Experimental directional drilling was done using an antifreeze thermal electrical drill (ATED) in a PICO test well. A special device called a whipstock was used for the deflection of the ATED in previously-drilled borehole. The test demonstrated that a whipstock deployed in the main borehole permits directional drilling to obtain extra ice core. The experimental whipstock was placed 25 cm above the bottom of the 4.5 m deep borehole. The ATED was inclined in previously-prepared cavity to an angle of up to 3°. When the second borehole reached a depth of about 6 m from the whipstock it had no inclination. The distance between axes of the main and secondary boreholes was about 0.3 m. The whipstock was frozen into the main borehole during directional drilling experiment and afterwards, it was heated electrically and removed from the hole.

1. Introduction

Increased interest by a number of scientific disciplines in the study of glacial ice has recently led to a high demand for ice cores. The difficulty and expense of obtaining sufficient quantities of high quality ice samples from great depths in glaciers can make interdisciplinary studies of only deep layers impossible. The problem can be partially solved by increasing core diameter, but this increases the expense of extracting the core, and the resulting material may not be adequate to address the scientific concerns. One of the main goals of glacier physics is the study of glacial ice under natural conditions of temperature, pressure and shear stress. Such research can be done by simultaneous deployment of sensors and transducers at specific locations in slanted and vertical shafts off the main borehole (Fig. 1).

One way to obtain sufficient ice from any depth in glacier is to extract it from slanted and vertical shafts after the main borehole is completed. Special tools are used in industrial drilling to divert the drill bit in specific directions (BROCK and CAGLE, 1992). However, the extremely high cost (>100000 \$) and complexity of the industrial technology make it unacceptable for the study of glaciers.

Positive results have been obtained by using simple whipstocks for deflection of the thermal drills in deep bore holes in Antarctica (Vostok Station). An electric hot point drill at a depth of 570 m was deflected up to 32° by the whipstock in a temperate glacier (Fig. 1). When the secondary borehole reached the bottom at a depth of 587 m the inclination had decreased to 29°. An additional 2.5 m ice core has been taken from the bottom (567 m) of Austfonna (Svalbard) cape (Fig. 2) by directional drilling (ZAGORODNOV, 1989). The secondary slant shaft was bored with a thermal drill after the whipstock was fixed at the bottom of the borehole. In the above examples, the new boreholes simply extended the

previous one. At present, deflection of mechanical drills in glacier boreholes is more complicated and has not yet been accomplished.

A new step in the development of DD technology is the design of a whipstock which can be placed at any given depth previously drilled deep boreholes.

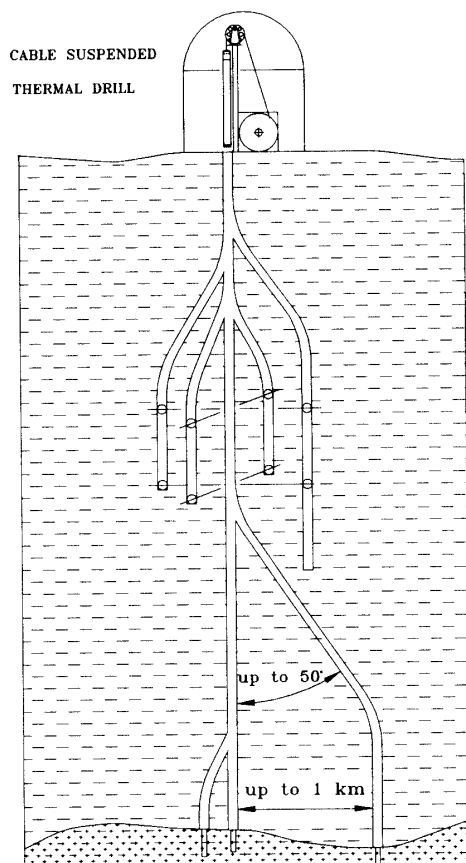

Fig. 1. Schematic of branch holes created by directional drilling technology.

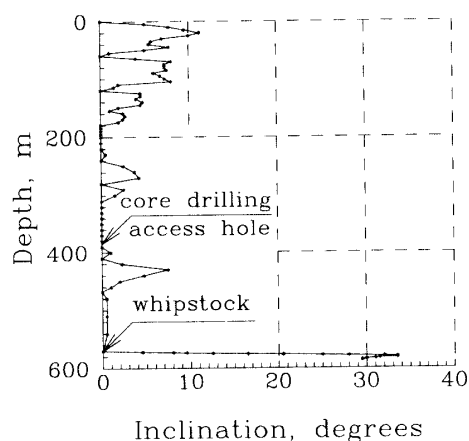

Fig. 2. Inclination of the borehole drilled with thermal core drill and hot point drill on Amundsenisen glacier, Svalbard, 1980.

2. Borehole Inclination

Experience has shown that during deep drilling any type of drilling equipment tends to deflect from the vertical usually with some negative consequences. When using an autonomous, cable suspended drill (Fig. 3) the drilling bit is always in the center of the kerf. Only upper part of the drill may touching the borehole wall. If the drill is not suspended by the cable then the borehole inclination increased. At some point in the time the middle portion of the drill will touching the borehole wall. From practical drilling we know that in such case the drill can not advance deeper (Fig. 3). Assume that the borehole trajectory is a segment of circle. Since the minimal radius (R_{\min}) of an inflexible drill trajectory has the following proportions:

$$R_{\min} = \frac{L^2 + 4D_1^2 - 4D_2^2}{8(D_2 - D_1)},$$

were L is the drill length; D_1 is the drill diameter; D_2 is the borehole diameter. A shorter drill can produce a smaller radius of trajectory. The length of an antifreeze thermal drill is 3–4 times less than any mechanical type drill. Hence, R_{\min} for such drill is 9 to 16 times shorter. From a practical point of view, this means that an antifreeze thermal drill can be deflected from the main borehole within a much shorter depth interval than a mechanical drill. A thermal drill with specifications as in Table 1 has an $R_{\min}=50$ m; the maximum inclination during 1 run (1.7 m) is about 0.5° . Hence, an inclined borehole can be straightened within a much shorter depth interval with a thermal drill than with a mechanical drill. The advantages of thermal drilling include the ability to make a cavity in a liquid-filled borehole. The drill can be turned at larger angle if the cavity has a length approximately equal to the drill length.

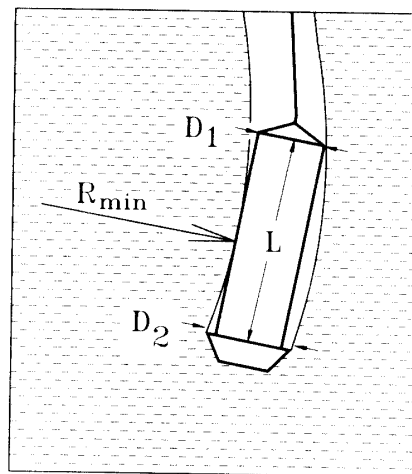

Fig. 3. Position of the thermal drill in the borehole.

3. Directional Drilling Experiment

3.1. Antifreeze thermal drill

The DD experiment was done with an antifreeze thermo-electrical drill (BOGORODSKY and MOREV, 1984) (specification in Table 1). The drill was raised and lowered in to the boreholes with Kavlar cable and 400-m winch. The same winch and cable was used for whipstock mounting and extracting. Because we expected relatively high ice temperature, near the melting point of ice, ethanol was not used to fill the borehole.

3.2. Whipstock

The main parts of the whipstock (Fig. 4a) are: a pipe with a sloping upper end, two clamping mechanisms for attaching the whipstock to the borehole wall, and devices for activating the clamping and releasing mechanisms. The whipstock has a 69-mm diameter hole through it. The drill bit is deflected by the sloping surface at the upper end of the whipstock pipe.

Table 1. Antifreeze thermal electric drill specifications.

Drilling bit outer diameter/ inner diameter	108/84 mm
Borehole/Ice core diameter	114–120/78–80 mm
Drill/Ice core length	2.0/1.6 m
Drill weight	40 kg
Power consumption	1.5–4 kW
Feeding rate	2.0–5.5 m/hr
Penetration rate (24 hr/day, depth 600 m)	540–420 m/week

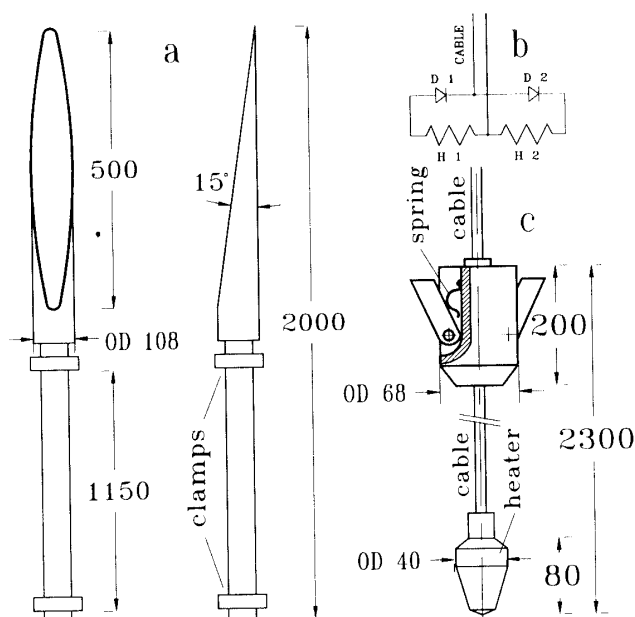

Fig. 4. Whipstock structure (a), electrical diagram of the whipstock (b): D1 and D2 are diodes, H1 and H2 are heating elements, and (c) structure of extractor device (dimensions in mm).

During directional drilling, it is critical that the whipstock be securely attached to the walls of the borehole. This is accomplished by 24 flat springs directed outward into the borehole wall and downward. Downward pressure on the whipstock forces the springs into the borehole wall, thus preventing the whipstock from sliding down (12 springs hold at least 800 N) but offer little or no resistance when pulling the whipstock upward out of the shaft. The springs also prevent the whipstock from rotations in the shaft. This whipstock can be used in 108–145 mm diameter boreholes. Electrical diagram of whipstock shown in Fig. 4b. Nichrome heating elements have 4 Ohm resistance and operate with 20–60 DC volts.

The whipstock attachment springs are activated when nylon strips are melted by electrical heating elements. The melting device was successfully tested in an ethanol-water solution at -25°C . Similar heating devices have been used for activating the cable-whipstock coupling mechanism. Commutation of the heating elements is accomplished by diodes when the polarity of the input voltage on the winch slip rings changes. During

deployment, the upper part of the whipstock is attached to the cable by a special cable connector and lowered into the borehole. The cable connector has a one pin electrical connection for operating the heat-activated releasing mechanisms on the attachment springs and for activating a release pin for detaching the cable from the whipstock after it is secured to the borehole wall.

3.3. Extraction device

The whipstock is a hollow aluminum tube with an inside diameter of 69 mm. Located inside the tube is a constriction which further reduces the diameter to approximately 65 mm. This permits the conical bottom end of the extractor (Fig. 4c) to slide into the whipstock past the constriction. Spring-loaded catch pins on the side of the extractor spread inside the whipstock, preventing the extractor from being withdrawn from the whipstock. If the whipstock is frozen into the ice or bound in by shear deformation, an electric heating element in the cone of extractor will melt the surrounding ice during the pass through the access hole. In our experiments, a 3 kW capacity electric element was used. When the whipstock is freed, it can then be lifted from the borehole.

3.4. Experiments

Experimental directional drilling was performed in the PICO test well (Fig. 5). The test well in permafrost has following parameters: 0.8 m in diameter, and 12 m deep. The well was fill with fresh water and allowed to freeze. The temperature of the surrounding permafrost is about -2°C .

A vertical, 120-mm diameter main borehole was drilled to 4.5 m depth with the ATED. The penetration rate was about 3 m/hr. The whipstock was placed at 0.25 m above

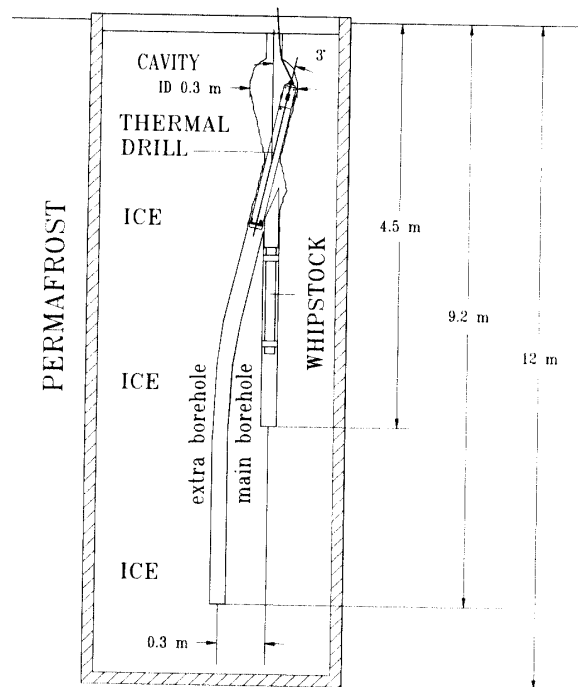

Fig. 5. Schematic of directional drilling experiment.

the borehole kerf and do not touch the hole bottom. Two cavities was prepared using the same thermal drill by holding the operated on full capacity drill bit stationary at 5 cm intervals for about 0.5 to 7 min at each depth. Both cavities were prepared in 4 hours. The secondary inclined boreholes was drilled at a penetration rate of 3 m/hr; ice core quality from the main and secondary holes was good. Boreholes parameters are shown in Table 2.

Table 2. Boreholes parameters.

Parameter	Units	Main borehole	Secondary borehole
Diameter	mm	120	120
Depth	m	4.5	9
Inclination	grad	0	0 to 3
Cavity diameter/length	m/m	0.3/1.5	0.3/1.5

Five days after placement of the whipstock, it was heated by the electrical element and extracted from the borehole. Heating element was lowered into the whipstock access hole and held for 4 min at 7 cm depth intervals. Along the upper sloping surface of the whipstock, the heater was held for 2 min at 7 cm depth intervals. Extraction required approximately 3.5 hours.

4. Conclusions

- 1) The whipstock prototype we tested is practical for antifreeze thermo-electric ice coring. No extra surface equipment needed for directional drilling.
- 2) Only eight extra hours were needed for placement (about 4 hr) and recovery (about 4 hr) of the whipstock in borehole.
- 3) The secondary borehole regains its vertical trajectory about 6 m down from the whipstock.
- 4) Whipstock can be recovered, even when the borehole freezes or is deformed by shear.
- 5) The angle of deflection of the secondary shaft depends on cavity diameter, but not on the slope angle of upper end of the whipstock. From previous field experiment the maximum angle of DD with 2 m length antifreeze thermal drill is estimated to be 40–50°.
- 6) The access hole in the center of the whipstock allows scientific equipment to be lowered for simultaneous use in one or more secondary boreholes.
- 7) Modifications of DD technology.
 - borehole logging equipment can be deployed with the whipstock placement device to permit DD in specific azimuth direction;
 - special heaters can be deployed to melt the cavities in 0.5 to 1 hr;
 - the whipstock can be deployed with rubber packer, which permits use of the ATED in boreholes filled with hydrophobic liquids (DF-A, kerosene, Butyl acetate).
- 8) Combined deployment of an electric thermal drill, a whipstock, and placing-logging equipment will make the following possible:
 - additional ice cores from any depth and azimuth;

- “fresh” ice cores from “old” boreholes: Camp Century (1966); Byrd Station (1968); Dye-3 (1981); GISP; GRIP, Vostok.

Directional Drilling technology can provide additional boreholes and ice core from any chosen depth at any time, making glacier deep boreholes a natural depository of ice and a laboratory for geophysical experiments.

Acknowledgments

We appreciate the financial support of the U.S. National Science Foundation. The authors are grateful to our colleagues from the Polar Ice Coring Office and faculty members of the University of Alaska Fairbanks, and to the Institute of Marine Science Publications Office personal for their assistance with editing and preparing this manuscript for publication.

References

- BOGORODSKY, V.V. and MOREV, V.A. (1984): Equipment and technology for core drilling in moderately cold ice. CRREL Spec. Rep., **84-34**, 129-132.
- BROCK, K.A. and CAGLE, W.S. (1992): New technology economically sidetracks cased well bores. *Petroleum Engineer International*, 51-54.
- ZAGORODNOV, V.S. (1989): Antifreeze thermodrilling of cores in Arctic Sheet Glaciers. *Ice Core Drilling; Proceedings of the Third International Workshop on Ice Drilling Technology*, Grenoble, France, Oct. 10-14, 1988, ed. by C. RADO and D. BEAUDOING. Grenoble, Centre National de la Recherche Scientifique, Laboratoire de Glaciologie et Geophysique de l'Environnement, 97-109.

(Received April 20, 1993; Revised manuscript received January 24, 1994)